

# JCRCC News March - April 2004

Volume 3, Issue 2

April 10, 2004

*2004 Officer List*

**President**

Joe Mosso

**Vice President**

Dirk Grossman

**Secretary**

Larry Dalkowski

**Treasurer**

Don Imbriaco

**Safety Committee Chair**

Dirk Grossman

**Contest Director**

Joe Mosso

**Field Committee Chair**

Pete Ellis

**Membership Committee**

Larry Dalkowski

Sty Hiller

**Video Officer**

Bruno Salamunia

**Web Site Designer**

Al Bruno

**Newsletter Editor**

Tom Cuccurullo

## Upcoming Field Events!!!

*WARBIRDS OVER SOUTH  
JERSEY JUNE 26, 2004*

*SAM EVENT SPOT 15  
JULY 17, 2004*

*2004 AMA DISTRICT  
FLY- IN OCTOBER 2-3*

Inside this issue:	
Club Calendar	2
Cartoons	2
Classifieds	2
February Meeting Minutes	3
March Meeting Minutes	4
Members Projects	5-6
Tips & Tricks	7
Upcoming Area Events	8

### Newsletter Content Wanted

To all JCRCC members. The newsletter has gone through some changes and I am now pretty comfortable with the format of it . I hope everyone is enjoying it and maybe even getting a little bit of use from it. I have been getting most of the tips and articles from research on the internet and am looking for something else now. The

newsletter is only as good as the content that is in it and I would like to get some content from our members. So if you have a story, tip, trick, cartoon, review, picture, caption, or anything else please get it to me and I will get it in the newsletter. Please be sure to include names with everything, even for people in pictures, I

do not know all the names of everyone in the club. You can submit your contribution using email, (TAC-001@att.net) regular mail, or in person. I can scan most pictures and text to get it in the newsletter so don't worry.

*Tom Cuccurullo (Editor)*

## Schedule of Events

- April 4th—Palm Sunday
  - April 6th—Passover Begins
  - April 11h—Easter
  - April 13th—Passover Ends
  - April 15th—Monthly Meeting 8:00pm
- To add a club event or an area event to next months newsletter please send an email with all the details to:
- Tom Cuccurullo  
TAC-001@att.net

Regular mail (see address on last page) and hand delivery are also accepted.

# April 2004

Sun	Mon	Tue	Wed	Thu	Fri	Sat
				1	2	3
4 Palm Sunday	5	6 Passover Begins	7	8	9	10
11 Easter	12	13 Passover Ends	14	15 Monthly Meeting	16	17
18	19	20	21	22	23	24
25	26	27	28	29	30	

## Classifieds

### For Sale:

Eleven - COX .049 Engines, lots of parts and props - \$50.00

Tiger Moth - 72" with 25 cc engine, no radio or servos - \$160.00

Call Harry, 732-255-5836

### Wanted:

O.S. MAX 25 FX Engine with muffler

Call Harry, 732-255-5836

## Cartoons

Ladies and gentlemen, this is the captain speaking. Firstly, I'd like to thank you for choosing to fly Mandarin Airlines. As we taxi out to the runway please make yourself comfortable... and for those of you sitting on the right side of the plane please look to your LEFT!



# February Meeting Minutes

## JERSEY COAST RADIO CONTROL CLUB

**Meeting Held at:**  
Wall Municipal Building,  
February 20, 2004

**Members present** 26

**Called to order** at 8:00 PM

**Adjourned at** 9:05PM

**Old business:**

Secretary's report read for January, motion to accept Bill Cramer second by Harry Jenkins. Treasurer's report read, motion to accept Al Bruno , second Tom Henks.

**Safety:**

No problems reported.

**Video:**

No report. We will be looking for a volunteer to take over shortly.

**Web-site:**

Nothing new. It was suggested that we have a memorial section with the names of life member that have passed on.

**Field report:**

Field is OK except for typical winter problems. There is a minor problem with the keys. The gate key will work fine for all keys but some will not open the shed. Till the problem is resolved please use last years key on the shed if needed. The 300 feet of new chain link fence has been installed. Great job by all involved, looks good.

**Contest committee:**

Contests to be announced at meetings and will be posted on the web site. Activity will increase with better weather.

**Prospective new members:**

Jack Sell

**New business:**

Ron Edgecomb has scheduled a fun fly for the kids at the First Baptist Church on April 17. Volunteers are need to fly trainers with the kids. Contact Ron if you can help out. Opening Day for the club is scheduled for May 23. Field clean up and maintenance are set for May 15 & 16. The field will be closed to general flying all day on the 15 th and part of the 16 th. Help is needed, if you have some time stop by. The Dulles bus trip has been canceled, not enough people signed up to cover costs.

**Crasher of the Month:**

None

**Model of the Month:**

Tom Henks- Model of Lewis machine gun  
Robert Adams- Pictures of his 1/4 scale Stinson Reliant

**Meeting adjourned at**

9:05 PM

For those of you that did not receive this month's newsletter in the mail it is because I do not have you on the list to have it sent to you. If you would like to receive a copy in the mail please fill out

**Please Fill Out And Return To Address On Last Page, Email Me, Or Give It To Me At The Next Meeting.**

NAME \_\_\_\_\_

ADDRESS \_\_\_\_\_

CITY \_\_\_\_\_ STATE \_\_\_\_\_ ZIP \_\_\_\_\_

E-Mail Address: \_\_\_\_\_

I wish to have a copy E-mailed to me.

I wish to receive a copy of the newsletter in the mail.

## *March Meeting Minutes*

### **JERSEY COAST RADIO CONTROL CLUB**

**Meeting Held at:**  
Wall Municipal Building,  
March 18, 2004

**Members present** 21

**Called to order at** 8:00 PM

**Adjourned at** 8:40 PM

**Old business:**

Secretary's report read for February, motion to approve Mel McKelvey second Al Bruno. Treasurer's report motion to approve Mel McKelvey second Roy Hulse.

**Safety:**

On the safety stands be aware of battery placement. One of our large scale pilot was running up an engine and had a automotive starter battery on the front of the stand. With the engine at full throttle the back end of the

stand lifted up off the ground. The throttle was cut before the stand went completely over. Please keep starter batteries on the ground until the stands can be staked down.

**Video:**

No report. A volunteer is needed to take over. If interested contact the executive committee.

**Web-site:**

There are some new scale links on the site, check it out. If anyone has pictures of our past life members contact Al Bruno, they are needed for the memorial on the site. Also if anyone runs across a dead link please let Al know.

**Field report:**

Recommend material for the road is ARD. Proposed cost is approximately \$400.00 per truck load. No motion on this proposal pending further investigation.

**Contest committee:**

No report

**Prospective new members:**

Leonard Cacciatore

**New business:**

The AMA District fly-in date is set for October 2 and 3. Joe Mosso had information on a Monmouth County Parks donation to 911 Memorial. No motion for approval.

**Crasher of the Month:**

None

**Model of the Month:**

None

**Meeting adjourned at:**

8:40 PM.

## **Member Input Needed**

The club will be setting up a memorial area on the web site. If there is anyone in the club that can provide a short paragraph telling about their accomplishments and their contributions to the club. Also if you have any photos please send them in as well.

*Frank Lashek*

*Jim Smithers*

# Members Projects

***Robert Adams***

***1/4 SCALE STINSON RELIANT***

PHOTOS OF 1/4 SCALE STINSON RELIANT FROM THE WENDALL HOSTETLER PLANS. PRECISION CUT KITS (LARRY KATONA) CUT THE WOOD. POWER IS BY A SEIDEL NINE CYLINDER 4 STROKE RADIAL ENGINE, 96CC (ABOUT 5.8 CU. IN.) THE AIRCRAFT IS FINISHED WITH FLITE METAL ALUMINUM, APPROXIMATELY 1500 RIVETS FROM MICRO-FASTENERS, 1/2" WIDE PINKED TAPE FROM Balsa USA. THE FABRIS IS SUPER COVERITE (UNPAINTED) WHICH WAS FINISHED WITH THE FOLLOWING: 1 COAT OF SIG CLEAR DOPE (BUTERATE DOPE) THINNED ABOUT 50% WITH M.E.K. WHICH WAS BRUSHED ON, 1 COAT OF MIDWEST PACTRA PRIME PREP PRIMER WHICH WAS BRUSHED ON, THREE COATS OF STITS "POLY-TONE" PAINT; THE FIRST 2 COATS WERE ROLLED ON AND THE THIRD COAT WAS SPRAYED WITH A HVLP GUN, AND TWO COATS OF GLOSS CLEAR POLY-TONE WHICH WAS PURCHASED FROM F&M ENTERPRISES.

WINGSPAN-125 5/8" WEIGHT

APPRX 45 LBS. TIME TO BUILD; SLIGHTLY MORE THAN ONE YEAR



# Members Projects

***Robert Adams***

***1/4 SCALE STINSON RELIANT***

Continued

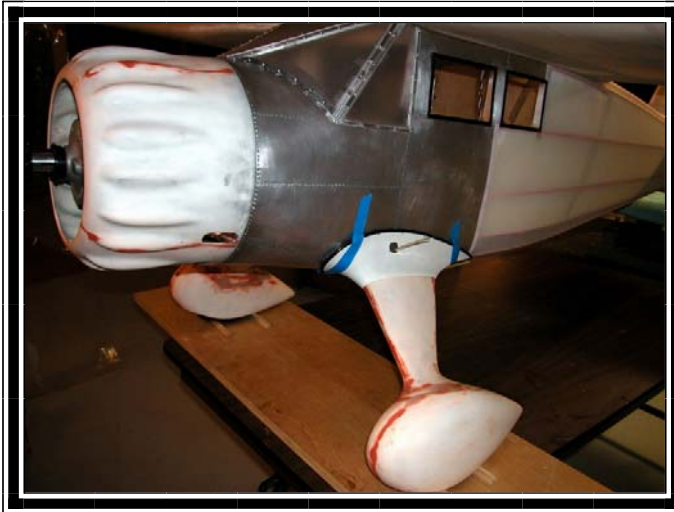

## Dihedral-How Much is Enough *Tips And Tricks* By Clay Ramskill

Like most things in the aerodynamic world, the answer to the above question is- "it depends". It depends on what you want from your plane; how maneuverable or how stable you wish it to be in the rolling axis, whether or not you desire the plane to roll when you deflect the rudder, whether or not you wish the plane to tend to self right when its upset from wings level.

In general, the more dihedral an aircraft has, the more it will tend to self-right to wings level when upset from straight and level flight. This little bit of roll stability makes the plane easier to fly because the pilot doesn't have to be constantly fighting to maintain wings level. Note the top two drawings in the figure - once we are no longer level, the lower wing is effectively a bit longer, and the lift forces on the lower wing are pointed more straight up. Also, since the figure shows a high wing plane, the CG of the plane is offset toward the high wing. All these situations tend to force the plane back to a wings level condition initially, before the plane begins turning or skidding sideways.

But the conditions described above won't last long. Also note that we now have the lift forces on the higher wing pushing sideways; this will cause the plane to skid sideways, turn, or both. Assuming no corrections from the pilot, what now happens is largely dependent upon the size of the rudder/fin combination! If the fin/rudder area is just right, the skid continues just enough for the dihedral effect of the wing to return us to wings level. Too much area in the fin/rudder, and we turn without skidding. Centripetal force from the turn negates all the self-righting effects, and we fly in balanced flight, but in an ever increasing wing and nose-down spiral - this is called spiral instability. Too little fin/rudder area, and the skid continues even as we pass wings level, resulting in over correction, and the plane rolls and skids, oscillating like a drunken sailor - this is called dutch roll.

Although the above discussion is more important to glider and free-flight pilots, it brings us to look at how dihedral affects a plane in skidding flight - and the good and bad sides of the dihedral effect. Note in the figure what happens to a plane with dihedral when in a skid, or unbalanced flight. This condition can occur with the pilots deflection of the rudder, or when a wind gust hits the plane from the side. The large discrepancy in angle of attack between the two wings causes the plane to roll away from the direction of the skid.

The dihedral effect is beneficial in self righting, gives us roll coupling with rudder application, and unfortunately, also gives us roll away from a side wind gust. Incidentally, sweeping a wing back also gives us dihedral effect - with about 5 degrees of sweep being equivalent to 1 degree of dihedral.

While roll coupling is essential to a trainer with no ailerons, its not good for aerobatic and combat aircraft. Most acrobatic and pattern models will have no dihedral. Military planes, with swept wings for speed, often use negative dihedral to counter the dihedral effects from the wing sweep - the Harrier, A7 Corsair, and C5 transport come to mind.

And while trainers usually have quite a bit of dihedral, and are wonderfully stable in normal flight, we've all seen them turn vicious in a gusty crosswind, during take off and landing, and even while taxiing on the field.

How much dihedral is enough?? For most of us, then, the answer is - Only enough to give us the roll stability we need, commensurate with our flying skills!

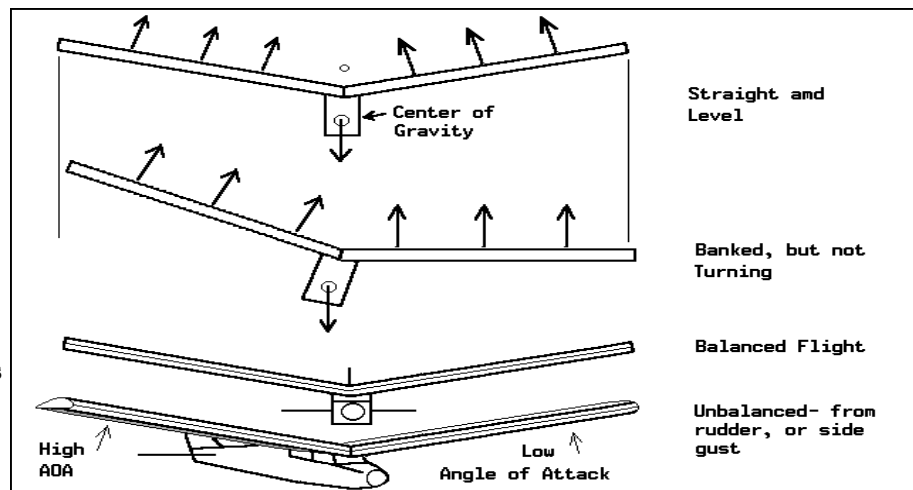

JERSEY COAST RADIO CONTROL CLUB

**Tom Cuccurullo  
PO Box 1734  
Wall Township, NJ 07719**

**<http://www.jerseycoastrcclub.com>**

*JACKSON HOBBY SHOP  
FULL LINE HOBBY SHOP  
THE PARTS & SERVICE SPECIALISTS  
HELICOPTER ACCESSORIES  
R/C EQUIPMENT CARS BOATS  
PLANES  
TRAINS ROCKETRY ACCESSORIES  
ARTS & CRAFTS TOOLS STAINED  
GLASS  
1/4 SCALE CARS  
PARTS & SERVICE  
PHONE - 732-364-3334  
RT. 526 BENNETTS MILLS PLAZA  
JACKSON, NJ 08527*

**This Month's Meeting is April 15th**

## **Upcoming Area Events!!!**

### **April 2004 Events**

#### **Scotland Flea Market**

PA

04/17/04 -Scotland, PA (E) Scotland Flea Market. Site: Scotland Community Center. For info and advance registration, contact Pat Frederick, 805 Antrim Lane Greencastle PA 17225 PH:717-597-2200. Wall tables \$12, aisle tables \$10 includes 1 admission. Admission \$4, refreshments available. Vendors setup 8AM, general admission 9AM to ??????. Additional info available at [www.http://users.planetcable.net/ppatterson/fleamarket.htm](http://users.planetcable.net/ppatterson/fleamarket.htm).

Sponsor: CHAMBERSBURG MODELAIRS

#### **Top of N.J. R/C Club Float & Seaplane Fun Fly**

NJ

04/24/04 - 04/25/04 -Mountain Lake, NJ (C) Top Of N.J. R/C Club Float & Seaplane Fun Fly. Site: Lisbon Capri Restaurant & Beach Area. Herbert Kircher CD, 42 Park Ave Cranford NJ 07016 PH:908-276-5056. This 2 day event is for float & seaplanes only, using a fly for fun format. There will be no contest categories, registration fee \$5, send S.A.S.E. for directions to flying site. Sponsor: TOP OF N.J. R/C CLUB